



MEGA
DETECTION
METAL DETECTION TECHNOLOGY

www.Megalocators.com

8

SEARCH SYSTEMS

- Complete Solution for Professional Treasure Hunters
- Unearth All Buried Deep Treasures Visually
- Completely New Powerful Detection Probes
- New Technologies : I.M.T.U , V.S.T , M.G.S
- Multilingual Easy to Use Software Program
- Bundled Android Tablet & 3D Analysis App



GMI MEGA
Geophysical Measuring Instruments

- Visual exploration of all Deep buried treasures
- All in one device to meet the needs of all treasure hunters

Complete Set of Detection Tools for Professional Treasure Hunters

GOLD STAR
3D SCANNER

GOLDSTAR
3D SCANNER

USER MANUAL

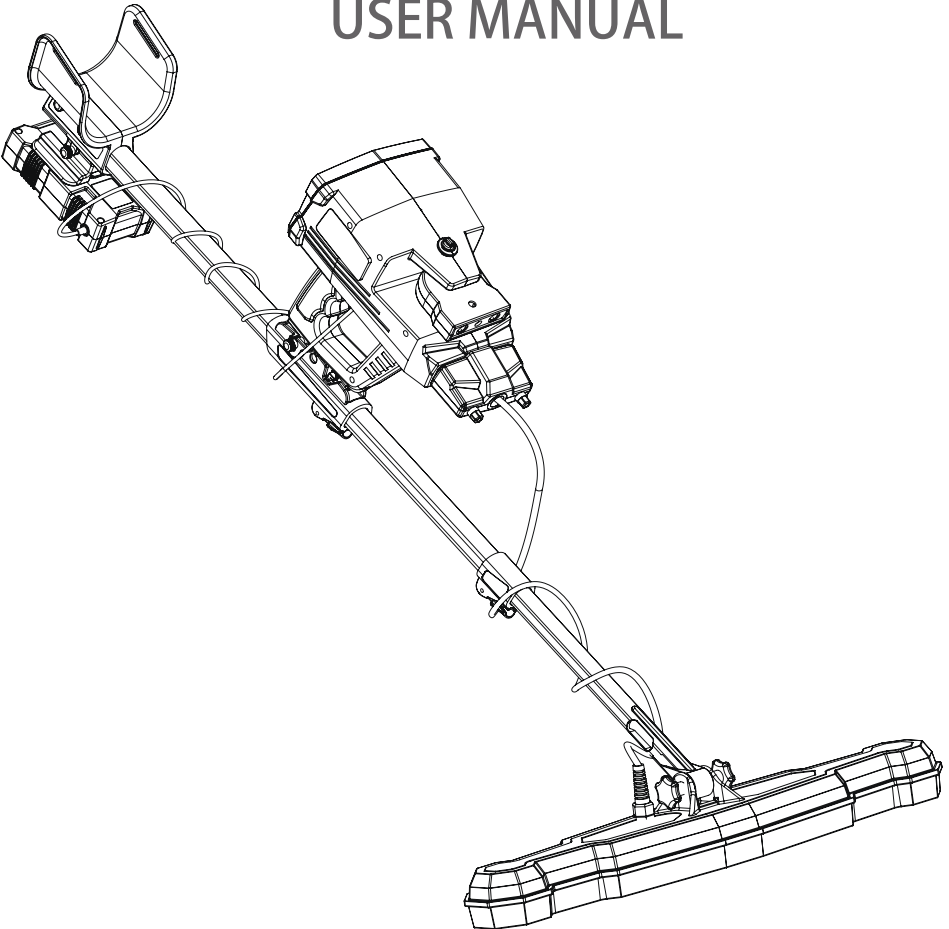

List of contents

Contents	2
Warnings	3
Property rights	4
Introduction	5
Package Contents	6
Overview	8
Assembly (I.M.T.U)	9
Assembly (V.S.T)	10
Assembly (Ground Scan)	11
Assembly (Stack Holder).	12
Panel Keys	14
Settings	15
Ground Scan System	21
Scan Files	26
Auto LRL System	29
Manual LRL System	32
CTRL LRL System	36
Ionic System	40
Bionic System	42
Live Stream System	44
Pin Pointer System	46
Multi Visual Analyzer	48
Customer Services	53
Technical Specification	54



Do not assemble and operate the device before reading the user manual.



The device may only be dismantled or repaired by MEGA DETECTION GmbH or its authorized service centers. Unauthorized disassociation / infiltration of the internal components of the main monitor or other units for any reason cancels the warranty.



Do not store the device and its components under extremely low or high temperatures for long periods (the preferred storage temperature is -20°C to 60°C / -4°F to 140°F).



Do not use the device indoors. The device may constantly give target signals indoors as there are many metals. Use the device outdoors, in open fields.



Do not submerge the device or its accessories in water. Do not expose the equipment to excessively moist environments.



Do not leave another detector or electromagnetic device close to the device (within a distance of less than 10 meters by 30 feet)



Protect the main unit of the device from impacts during normal use. For transportation, place the detector carefully in the original carton and secure with shock-resistant packaging.



Keep the device out of your shoes while walking. The device may detect minerals on you or inside your shoes as targets.



No part of this guide may be reproduced, including the products and programs described in it. Any use of material, reproduction, storage or translation of this information without prior permission from MEGA DETECTION GmbH is subject to legal liability of its owner.

MEGA DETECTION invites all users to ensure that the acquisition and use of this type of equipment complies with the laws and regulations of the countries in use and is not responsible for the legal consequences if the laws state otherwise.

MEGA DETECTION does not bear in all cases or any of its directors, officials, employees, and authorized agents indirect, special, incidental, or consequential damages (including damages for interest loss, business loss, loss of use or data, business interruption and the like), even if the company was notified of the possibility of such damages arising from any defect or error in this manual or product.

The specifications and information contained in this guide are published for information use only and are subject to update periodically at any time without notice to the user.

The products and company names that appear in this guide may be registered trademarks and copyrights are reserved for the related companies and mentioning them here is used only for identification and for the benefit of the owner, without intentionally infringing on the property rights of these companies.

MEGA DETECTION is not responsible for misunderstanding this manual or misusing the device in violation of the instructions in this guide.



Copyright © Mega Detection (© 2021 All Rights Reserved)



With the engineering, research and development team at Mega Detection, a dream is now a reality with Gold Star 3D Scanner.

A comprehensive metal detector with multiple detection technologies within one device that provides prospectors with all the necessary tools to detect buried treasures.

The integrated Gold Star 3D Scanner contains eight different systems to search for gold, metal and ancient archaeological burials with advanced technology and easy to use at the same time.

Ground Scan System

Auto Long Range Locator System

Manual Long Range Locator System

Control Long Range Locator System

Ionic System

Bionic System

Live Stream System

Pin Pointer System

Thank you for choosing the Gold Star 3D Scanner product from Mega Detection. For more information, you can visit our website.

PACKAGE CONTENT

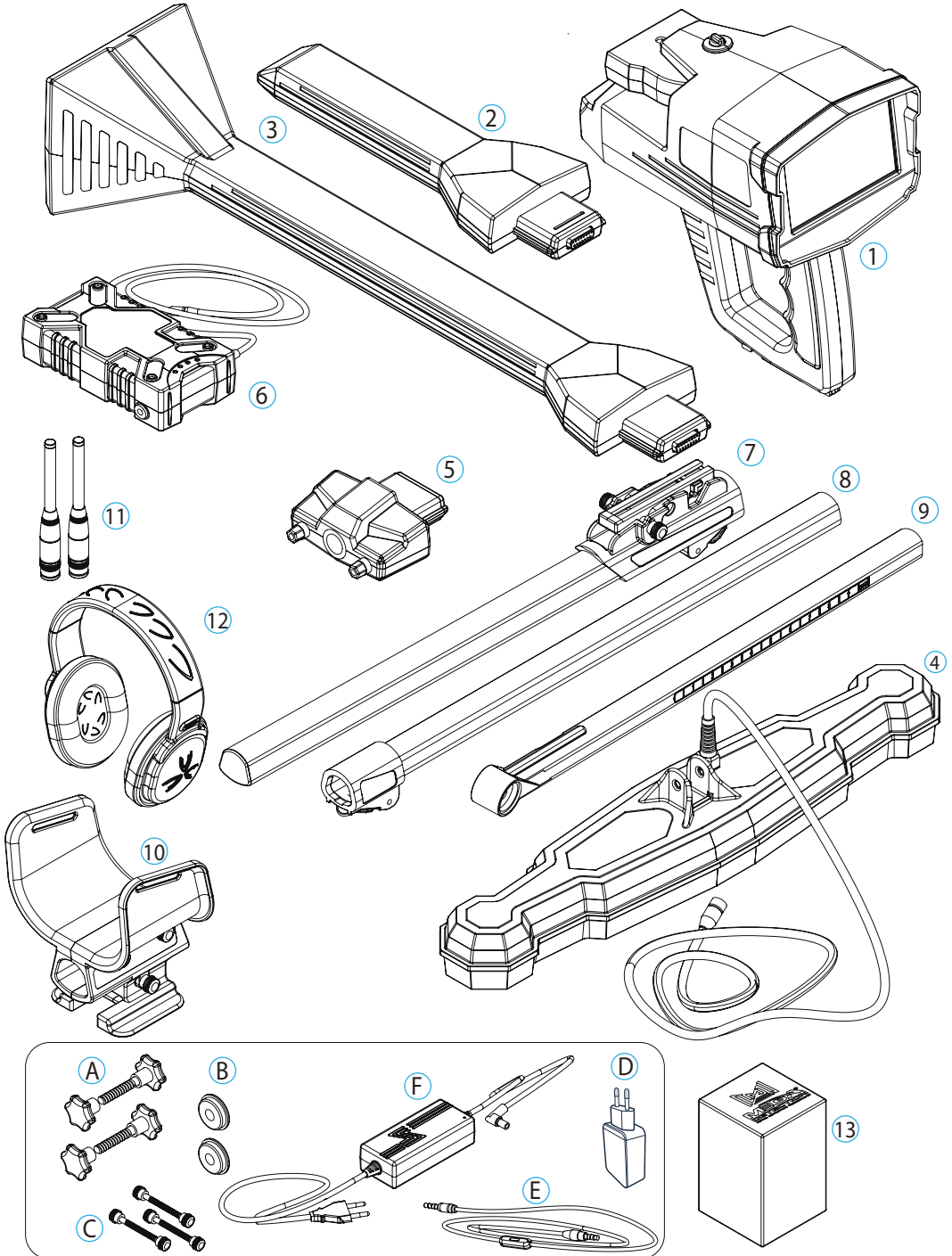

1	Main unit
2	IMTU Sensor
3	V.S.T Sensor
4	M.G.S 60 Scanner
5	Conector Base
6	Lithium-Ion Battery
7	Higher Stick (Shaft)
8	Medium Stick (Shaft)
9	Lower Stick (Shaft)
10	Armrest (Holder)
11	Long-Range Antennas (x2)
12	Headphones
13	Accesories Box including: <ul style="list-style-type: none">A. M.G.S Screw and Nut (x2)B. Washer for Plastic Stick (Shaft)C. Armrest (Holder) Screws (Spare Parts)D. Universal Power AdapterE. Headphones CableF. Battery Charger (220V)

OVERVIEW



IONIC SYSTEM
BIONIC SYSTEM

AUTO LRL SYSTEM
MANUAL LRL SYSTEM
CTRL LRL SYSTEM



LIVE STREAM SYSTEM
PIN POINTER SYSTEM



GROUND SCAN SYSTEM



Auto LRL
Manual LRL
Ctrl LRL
Ionic System (without No 1)
Bionic System (without No 1)

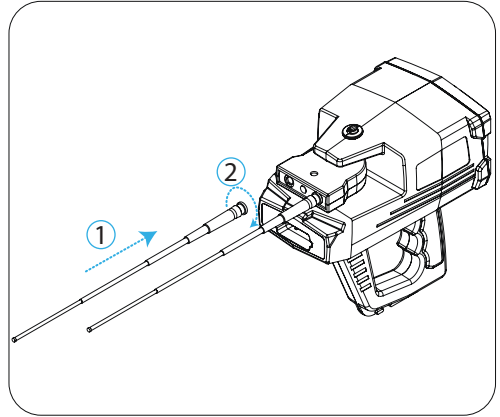

1 Connect the antenna on the device as it shown at the picture

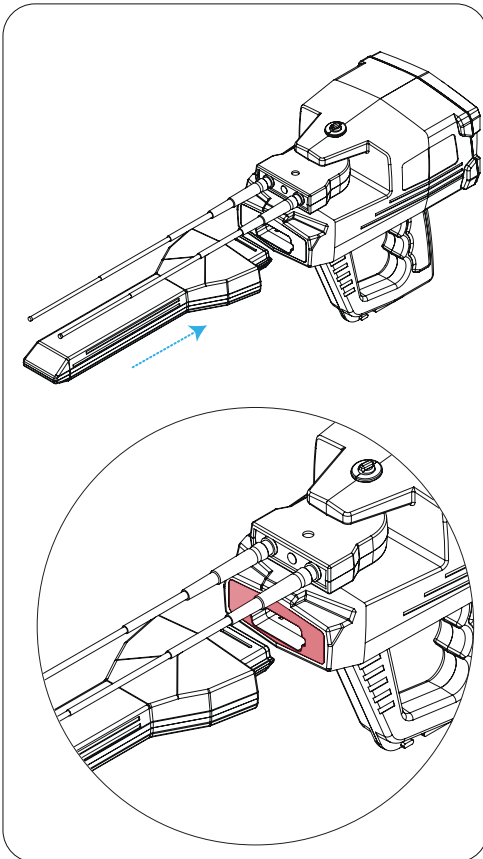

2 Connect the I.M.T.U Sensor on the device

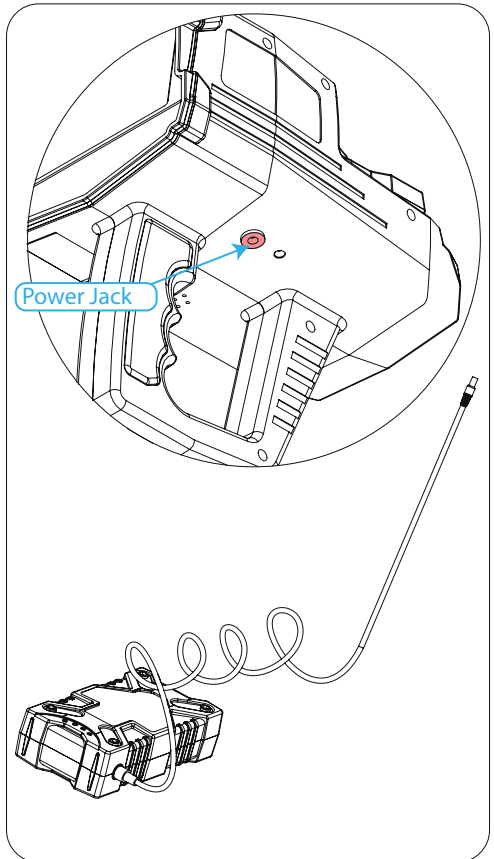

3 Use the power jack to connect the battery

Live Stream System Pin Pointer System

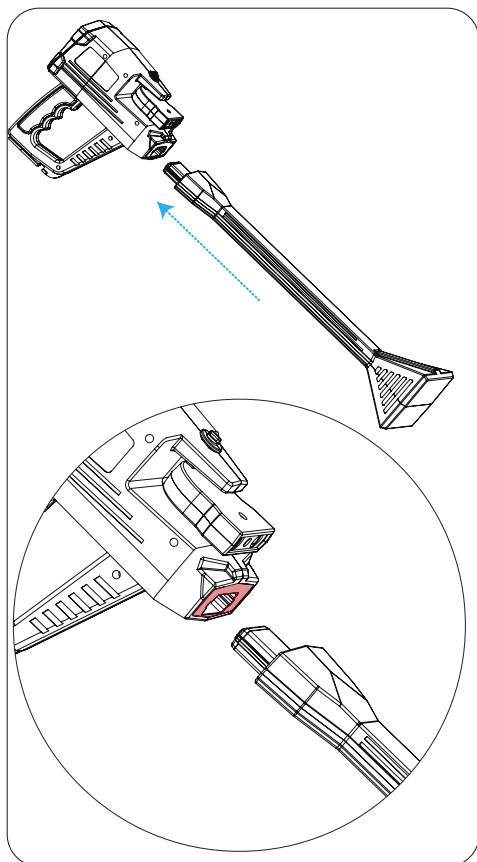

1 Connect V.S.T Sensor to the device as it shown in the picture

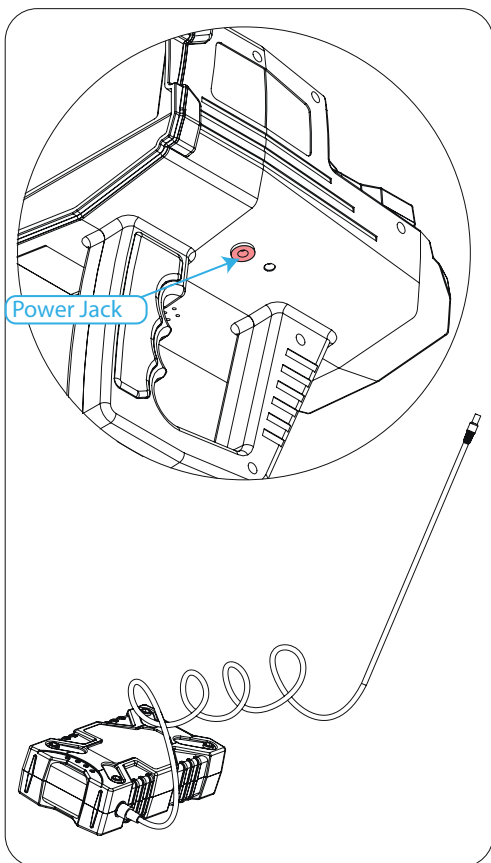

2 Use the power jack to connect the battery

Ground Scan System

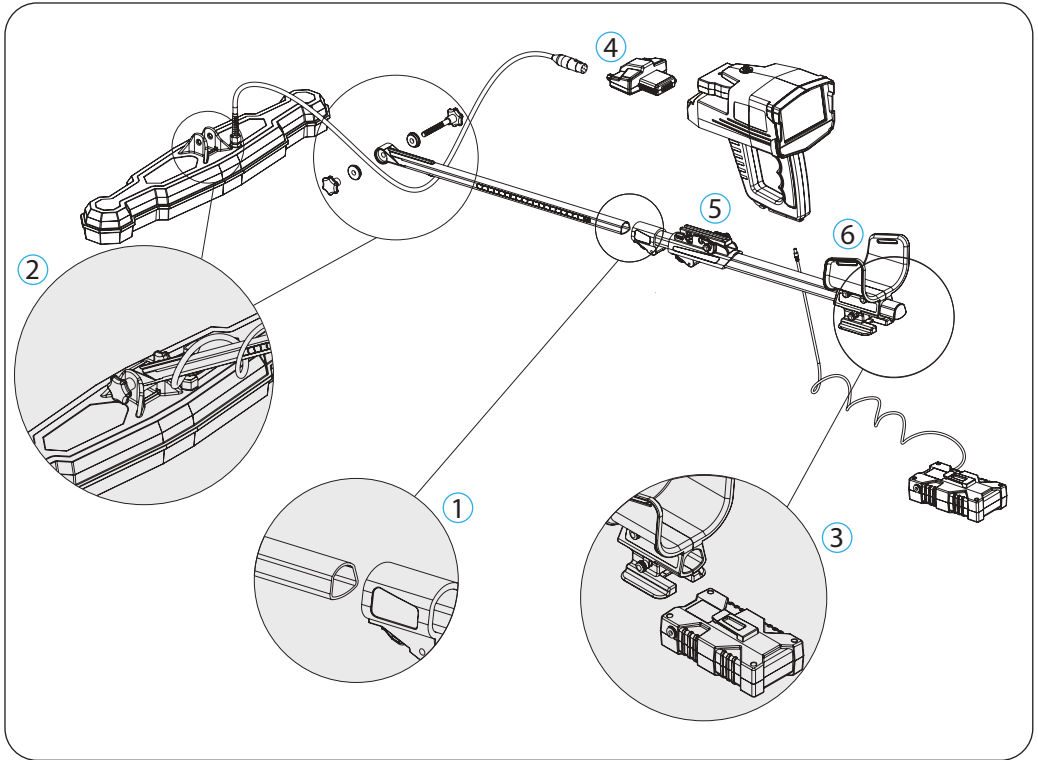

- 1 Attach the medium pipe inside the higher pipe.
- 2 Assemble the scanner and the lower pipe using the specific screw and nut.
- 3 Attach the battery to the hand holder so that the battery clip is in its specific place
- 4 Connect the scanner cable into the connector base
- 5 Put the device on the holder as it shown in next page
- 6 Connect the battery to the device

Attach the main unit on the holder

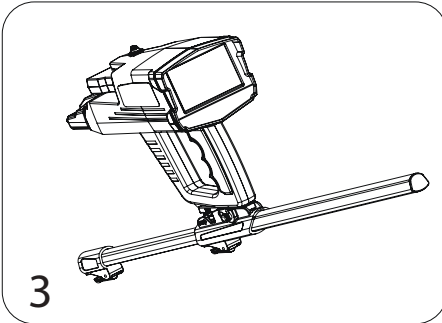
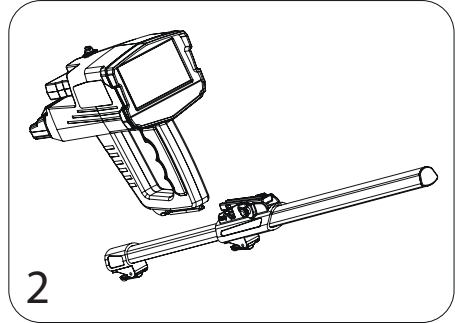
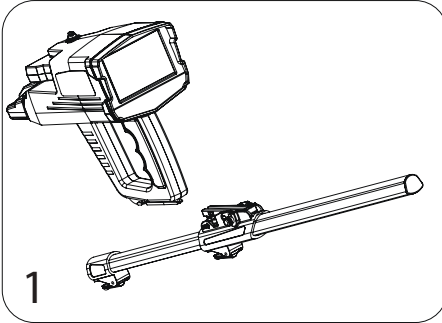

- 1 Prepare the main unit and the stack unit
- 2 Fit the main unit and the holder rail as Parallel position
- 3 Put the main unit into the rail until you hear a sound come from the lock pin

De attach the main unit from the holder

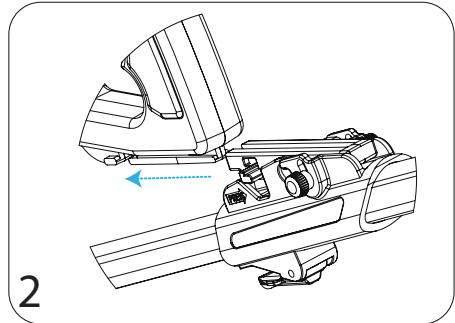
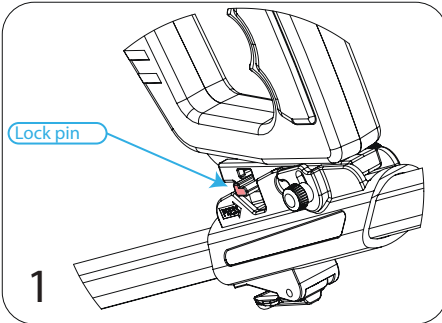

- 1 Press the Lock pin on the holder
- 2 Pull the main unit to front side

To fit the view degree of main unit on the holder, there is an option users can use. This option helps to fit device position on holder that users can see the display screen as well as possible.

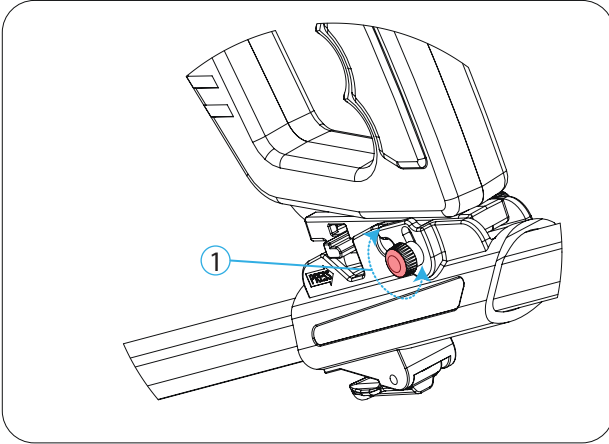

1 Unscrew the screw on the holder counter clockwise

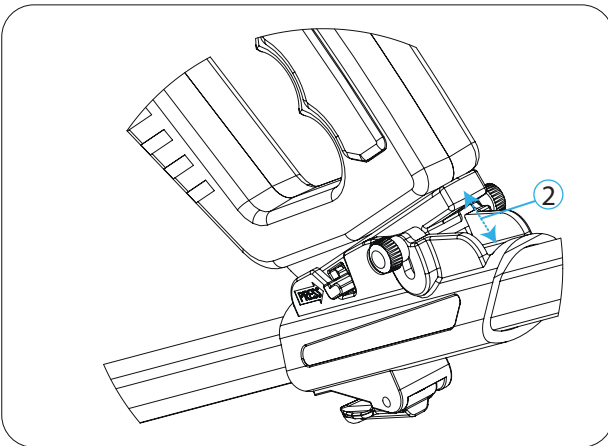

2 fit the main unit as the preferred degree and Close the screw again



1.  Power Key

2.  Back Key (Backward)

3.  OK Key

4.  Home Key



5. Control Settings Arrow Keys (Right - Left - Up - Down)

Power ON

To power on the main unit, connect the battery to the main unit then power on the battery by pressing one time on battery power button, then press on  on the main unit.

Power OFF

To turn off the main unit, just press the power key , when confirmation message appears, choose "Yes" to confirm, or "No" to cancel. after power off the device press two time on battery power button to power off the battery.

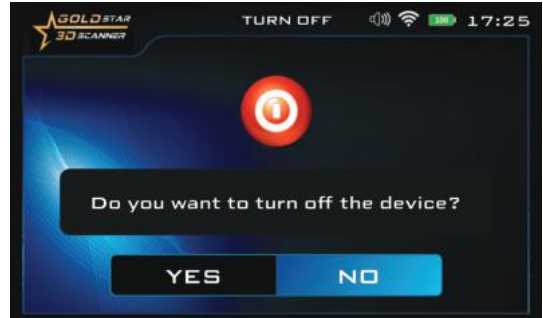

Adjust Settings

You can set the device setting by selecting Settings from the main menu



You can choose other options in the screen using   arrows

Go on setting icon and press 

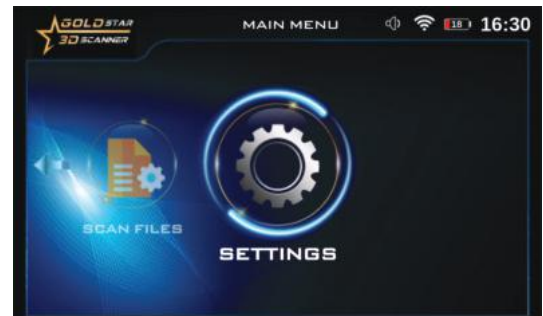

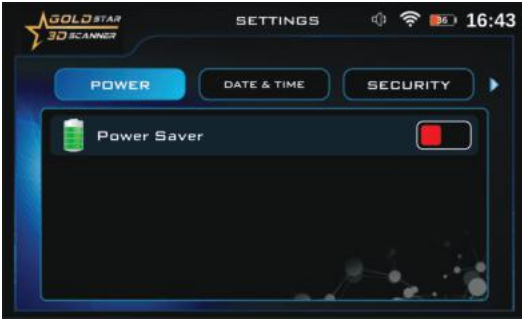

POWER

Use this option to save power when using the device.

With this option, the battery life can be increased by at least 50% , it depends on the search system and the type of connected probe

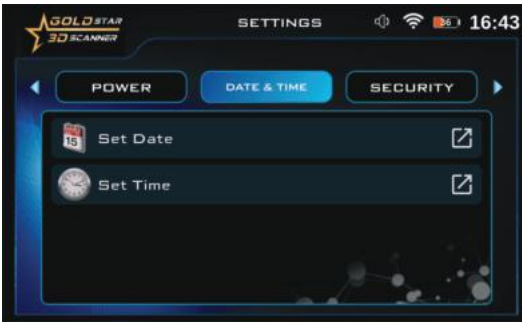



DATE & TIME

Date

1. Use the left/right   arrows

To select "date & time" item then press 



2. Use top/ down   arrows to select "Set Date" then press 

3. In this window use arrows to select the Correct date then after setting each one Press  to save



4. After adjusting the setting press  back on device controls key

Time

1. While you are in date and time setting menu use top/ down  arrows to select "Set Time" then press 
2. In this window use arrows to select the correct time then after setting each one press  to save

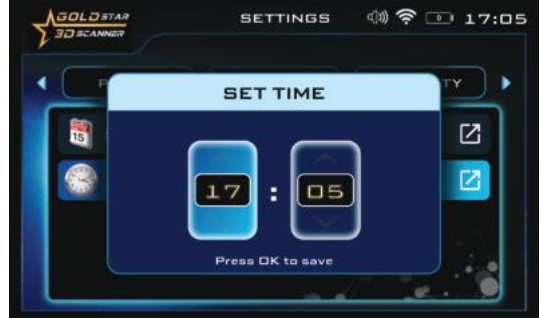

After adjusting the setting press  back on device controls key

SECURITY

To activate the device's security settings, you must click on the security lock  option within the security settings.

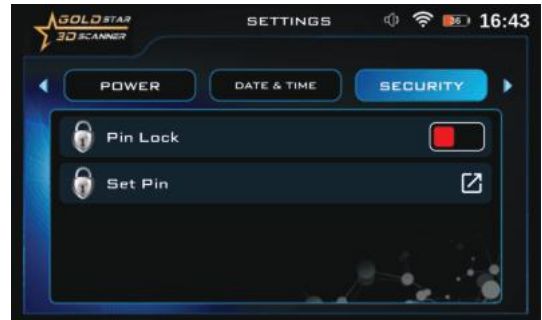

After activating the previous option, the security lock code can be set by the "Set Security Code" option.

When operating the device for the first time, the device will ask you to enter the security code (device password), which you get from the manufacturer or through the authorized distributor of the device in your country.

The security lock option can be locked in the device so that the device does not require the entry of the code after each operation





RESET

You can use this menu to reset the device Settings.

There is three type of resets

1. Reset settings:

By using this option all settings in The device will back to the default Settings, but the you will keep the Information saved in the memory

2. Factory Settings

With this option, all settings in the device will revert to the factory defaults and the memory data will be erased

2. Clear Memory

By using this option the memory Data will be erased

After selecting the reset option, a confirmation window will appear. By clicking "Yes" in this window, the reset will be done.

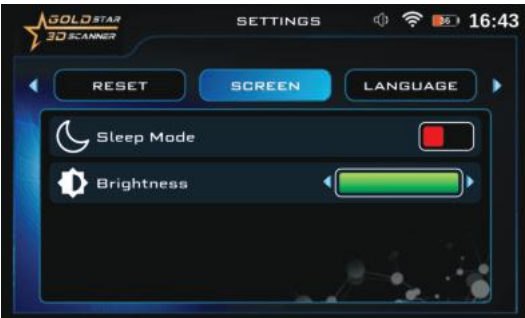

SCREEN

you can control screen settings using this menu.

Sleep Mode:

By turning on this option, the device's screen will go to sleep in the absence of any activity.

Brightness

user can control screen brightness using this option.

LANGUAGE

The device software interface is available in 12 languages, namely:

1. English
2. German
3. Spanish
4. French
5. Italian
6. Russian
7. Turkish
8. Chinese
9. Hebrew
10. Urdu
11. Arabic
12. Persian

To change the language, the user has to go to the language tab, then choose "Change Language" using the Up / Down arrow keys, then press OK, then choose the preferred language using the Left / Right arrow keys, then press OK

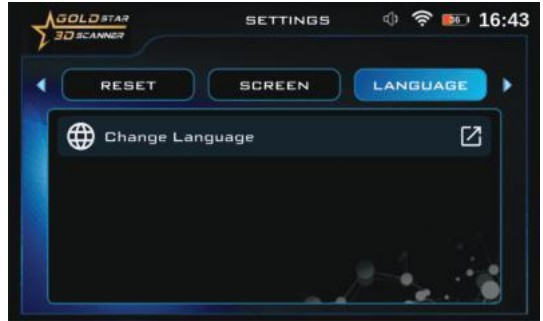

SOUND

User can control the device's sound status using this menu.

General Volume Level:

Use this option to control the sound of the whole device.

Keypad Volume:

Use this option to control the keypad sound volume

Scan Volume:

Use Up/Down arows to select the sound setting you need to change and then press on OK then use Left/Right arows to change the sound volume





INFO

This screen includes all device information

1. Device Version
2. Software version
3. Device Model
4. Serial Number
5. Country of manufacturer

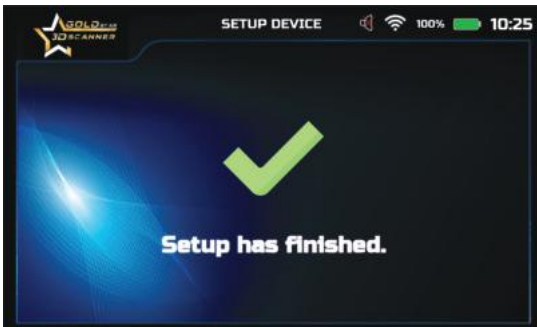

After completing all the setup processes, the following window will appear on the screen

GROUND SCAN

The ground scan system is a completely new system in new Mega Detection devices with new and improved technology.

This system helps the user to scan the ground and create a 2D visualization on the device screen or 3D visualization on any supported android tablet via Multi Visual Analyzer app.

This system can make searching and finding burials and underground cavities such as tunnels and basements easy for the user, with greater speed and accuracy.

Select the system

To start using ground scan system, select this system from the main menu.

Notice

Immediately after entering any search system from the main menu, A video will appear which notify the device's assembly steps. In case of any mistake in the assembly or installing a wrong part that does not fit the selected system, a warning video will appear on the device's screen regarding the exact error



After selecting the "Ground Scan" system from the main menu, a new screen will appear to select the device on which the results will be displayed.

There are two options: "Device" and "Tablet".

Selecting "Device" in this list means that the user can see results directly on the device screen.

Selecting "Tablet" in this list means that the user can see the result on the tablet device that came with the device that includes Multi Visual Analyzer application to display the results visually



Setup to Display Results On Device Screen

Mode

On this screen the user can choose the scan mode and there are two options:

Manual Mode

the user performs the scanning process manually, that is, he records measurements manually at each scan point



AUTOMATIC MODE

In this case, the device will automatically scan the points without user intervention, as it scans the points automatically with an interval between each point. User only has to press on start button at start of next scan line.

To choose the appropriate scan mode, use the Left / Right arrow keys, then press the OK key



Path

On this screen, the user can specify the direction of the scanning path, which includes two options:

1 - One Direction: the ground scan is performed for each line with the same direction, i.e. the direction of the scan is according to parallel lines and a distance between them

2 - Zigzag: In this case, the start of the next scan line is at the end of the previous scan line (while leaving an offset distance), meaning that every two successive lines are scanned in an opposite direction.

Select your preferred scan path mode using the Left / Right arrow keys, then press the OK key



Size

The user can choose the dimensions of the scanning area using this screen, which are:

Width (Lines)

It is the number of scan lines and can be set using the Up / Down arrows, then press the OK key

Height (Steps)

This number expresses the number of scanning steps or points for each line, and it can be changed by using the Up / Down arrows and then pressing the OK key

To understand the difference between lines and steps, look at the following figure:

When the user stands straight in the search area, every step he takes forward is called a scan point or step, and every time the user moves to the left or right, it is called scan line, meaning he moves to a new scan line.

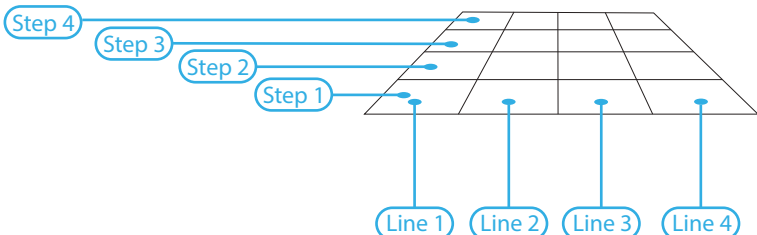

Start Point

Here the user can specify the starting point of the scan within the area and there are two options:

Left: The start of the scan is in the lower left corner of the scanning area

Right: The start of the scan process is from the lower right corner of the scanning area
The location of the starting point can be selected using the Left / Right arrow keys, then pressing the OK key



Scan

After completing all the previous settings, the user will see a screen showing the settings chosen through the previous steps

You can press the button at the bottom of the screen "Press OK to Scan" to actually start the scanning process.



How to Use

After the setup is complete, make sure that the device is fully and correctly assembled.

Hold the device in the following manner, and make sure that you are holding the device fixed to your body without moving, then stand on the zero or starting point in the scanning area and press the start button located under the handle of the device.

Keep the M.G.S height steady while scanning, at approximately a constant distance from the ground.

Make sure to record the scan point at each point by pressing the start button in manual mode before moving to the next point.

The minimum area of a rectangular scan area must be observed, as it must be at least 3 x 3 meters in size, and it is preferable that the dimensions of the scan area be (3 x 3), (6 x 6) or (9 x 9), with a 30 cm distance between each scan point.

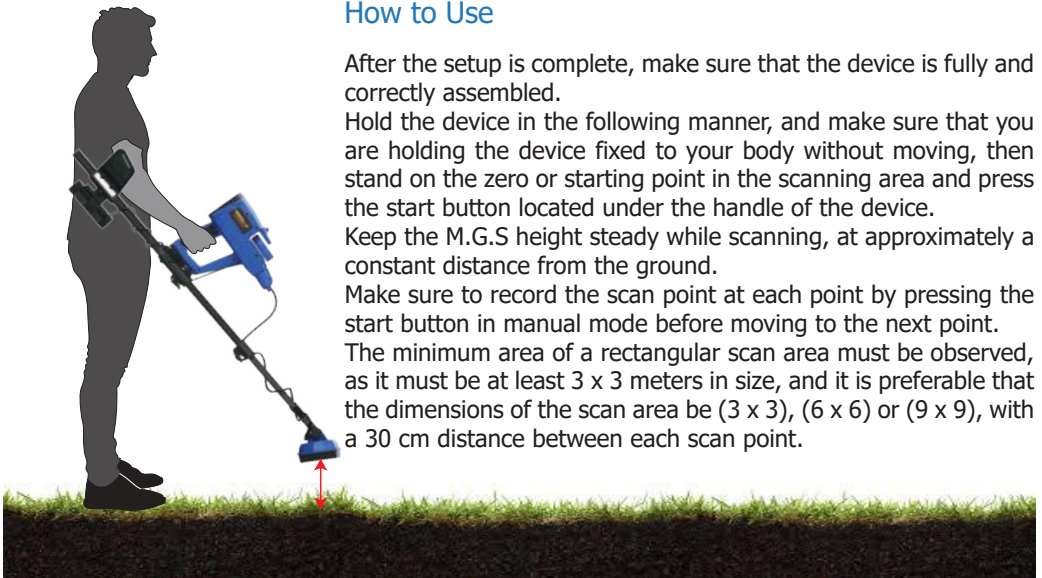

GROUND SCAN

If there is an uneven area of land, first clean the area and arrange it as flat as possible before performing the actual scan.
Continue scanning step-by-step according to the scanning path you selected, (One Direction or Zigzag)

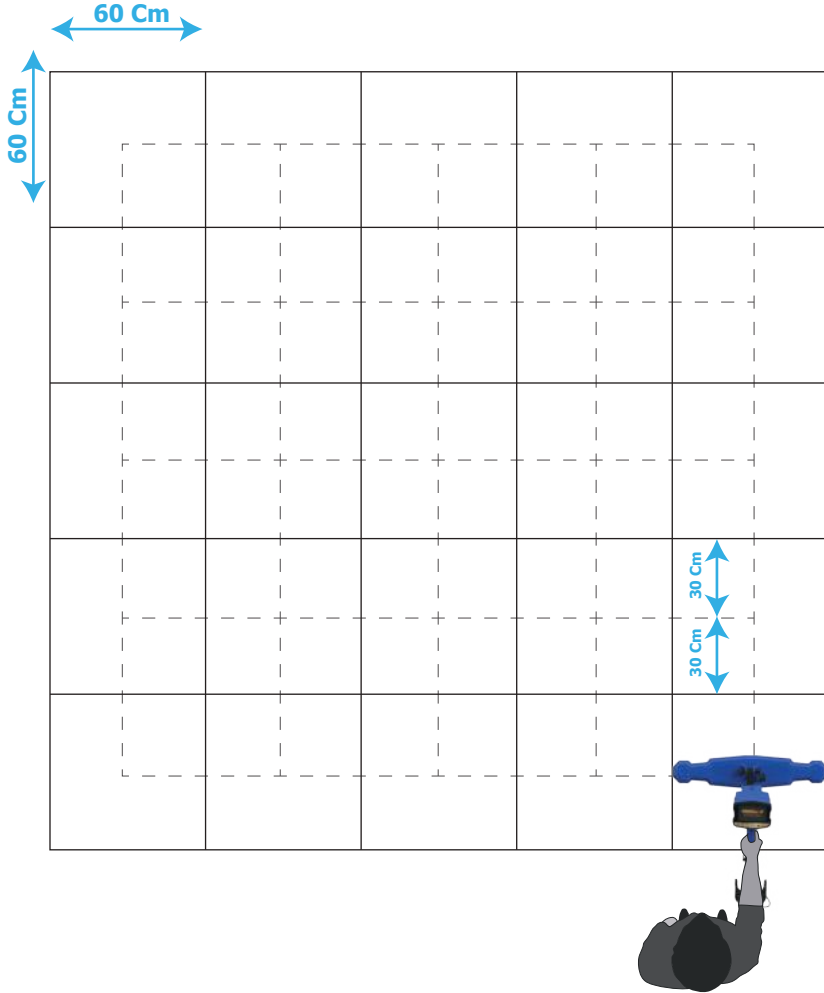

After each line of the scanning process is completed, you will see an alert on the screen which means you have to start a new scan line.

Change your position to the beginning of the next line and then press the start button located under the handle of the device.

On the screen appears a window that includes a grid of cells according to the number of lines and steps previously set.

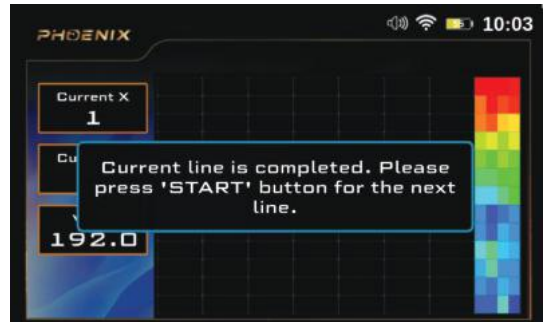

In the right pane, you can see information about the current step, current scan line and a numeric value of the probe during the scanning process

Line No

Step No

Search Value



When the scanning process is completed, you will see an alert on the screen stating that the scanning process is complete, press OK to exit

During the scanning process, you will see the color change of each cell of the grid according to the current scan point according to different colors. The user can know whether there is a target under the scanned ground or not by the color of each cell.

Notice

In Ground scan system, the device was provided with a special technology, which is the possibility of full control of scan process through the Multi Visual Analyzer app. for more information follow Multi Visual Analyzer description on this user manual



Green: normal natural ground



Light Blue: a small cavity



Blue: a large voids like a tunnel



Yellow: a small piece of metal object



Red: gold or large pieces of metal target

Scan Files

The device includes a memory to save scan results as files.

This means that the user can open a previous scanning process and re-display and analyze the results at any time, even when the device is not in the original scanning area.



Select the system

You can choose the "Scan Files" option from the main menu, then press the OK key, and a new screen appears.



This screen includes a list of all the saved files that you can open and review.

Use the arrow keys to select the saved file, then press OK

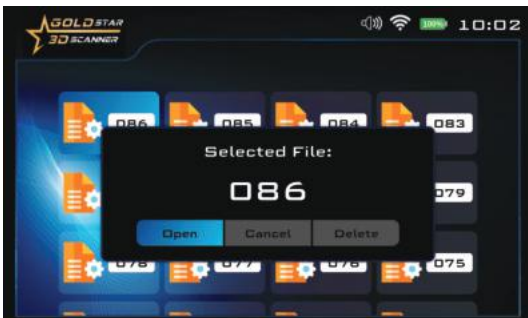

Every time the user selects a file, a popup window appears with three options:

Open: Select this option and then OK to open the saved file

Delete: Select this option to delete the current file

Cancel: Select to cancel opening the file and return to the file list.

Delete File

In case of selecting delete from the options the next view will appear. user can confirm delete presses using this window.

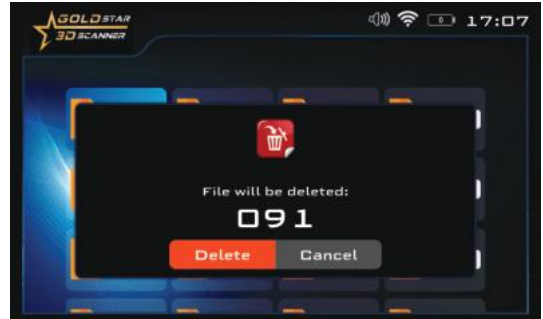

Screen Grid

This option shows or hides the grid lines that represent the scanning area, where each cell represents one scanning step (scan point)

Selected Tile



Choose a Cell From The Grid

Use this option to select a specific cell from the scanning area grid within the scanning results screen.

After clicking on the search icon, use the arrow keys on the keyboard to select a specific cell.

To return to the scanning tools, press the back button



Depth
0.08

Notice

The user can press the start button on each cell to display the exact result value for each of the M.G.S 60 built in sensors on result screen.

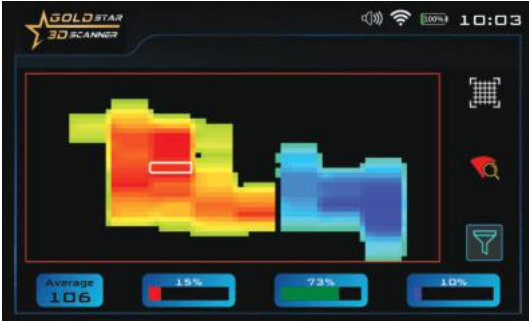

Color Filter

Use this option to hide or show the green color (presenting normal ground), and this is useful for showing useful areas of the scan area that include metal targets or voids.

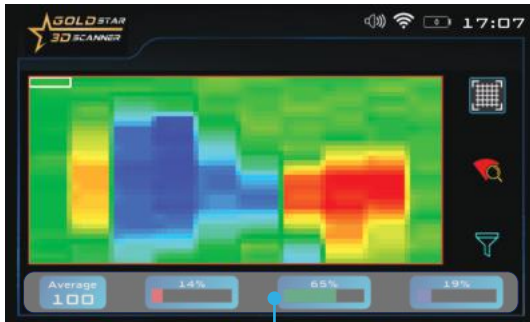

Average of all scanned data

Depth on each tile

Red Percentage

Green Percentage

Blue Percentage

At the bottom of the scan results screen, an information bar is displayed that includes several text fields that display information about the selected cell from the grid, making it easier for the user to analyze the results.

Color Ratios: the three-color bars (red - green - blue) represent the percentages of each target type within the specified cell from the scan area.

Average: This field represents an average value of all values in the detected points.

Depth: When the selection is made on the cell, the depth value will appear in the lower information bar, and the user can see the depth in each cell with this option. On the other hand, this value represents the depth value in the selected cell on the results screen.

Automatic Long-Range Locator System [AUTO LRL]

It is an advanced search system that covers a large scan distance within a very wide scan area within the specified land.

This system automatically searches for buried metal targets within the scan area according to the settings that are set in advance.

This will reduce the search area as much as possible, saving effort, time and cost for the prospector.

Select the system

To start using the automatic long range locator system, select this system from the main menu and then press OK key

After system selection, a screen will appear which includes couple of tabs to set the settings for this system, which are:



Notice

Immediately after entering any search system from the main menu, A video will appear which notify the device's assembly steps. In case of any mistake in the assembly or installing a wrong part that does not fit the selected system, a warning video will appear on the device's screen regarding the exact error



Distance

The device can search for targets for a distance of up to 3000 meters, and the user can change the distance value with the Up / Down arrow keys

Depth

It represents the maximum depth that the device will search for targets within the range from 0 to 100 meters and you can choose from predefined values using the arrow keys

Notice

After assembling the device and before start to scan
 Make sure that the antenna holder lock is locked
 To fix the antenna holder with the device.

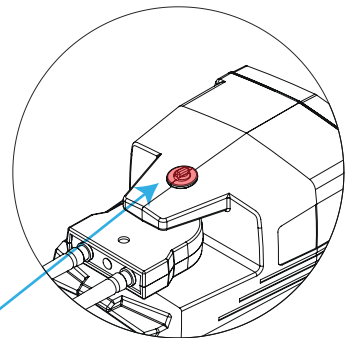

Antenna Holder Lock

How to Use

After the setup is completed, hold the device, as follows, and make sure that you are holding the device fixed to your body without moving, then stand in the search area and press the OK key on the keyboard to start the scanning process.

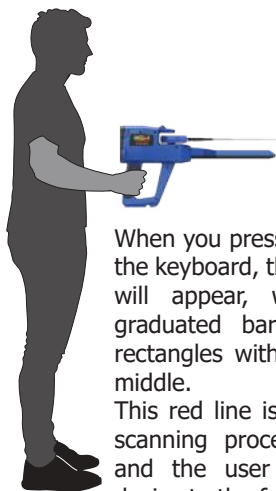

When you press the OK button on the keyboard, the following screen will appear, which includes a graduated bar graph made of rectangles with a red line in the middle. This red line is the center of the scanning process, or degree 0, and the user then directs the device to the front side.

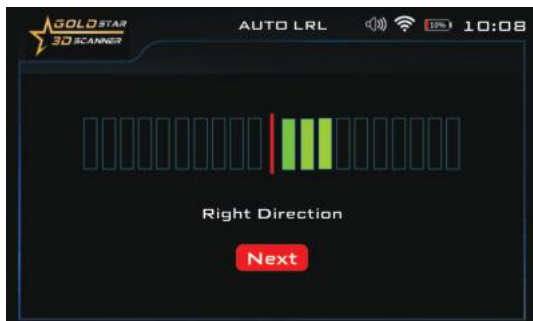

During the scan process, the user stands at a fixed point and moves the device only from the center to the right side slowly according to the indicator at a rate of 90 degrees, when reaching the far right, the user begins to return at the same speed from the far right to the center.

Immediately after the indicator and the user reaching to the center, the indicator will start to go to the left side and the user will also direct the device to the left side according to the indicator also at a rate of 90 degrees, when reaching the far left, the user begins to return at the same speed from the far left to the center.



Left Direction



Right Direction

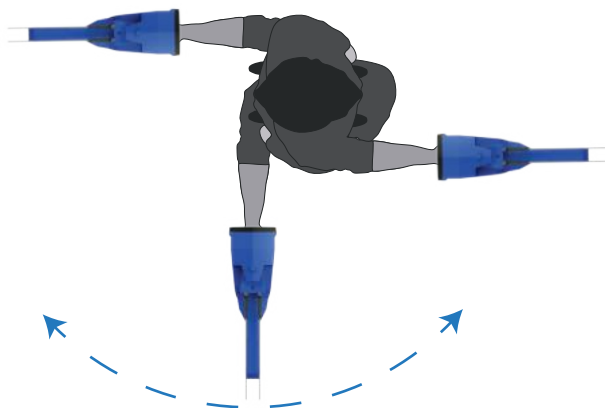

In this system, the user covers 180 degrees from the perimeter around him without moving from his place, only moving the device according to the indicators on the screen.

REPORT

After completing the search in the area, you can click on "Next" by pressing the OK button, to move to the results report.

Using this report will help determine whether or not this area contains any valuable target.

You can see four types of targets in this screen (Gold, Silver, Iron, and Diamond).

The percentage of each shows the probability ratio of the discovered target and through it the nature of the target can be known.

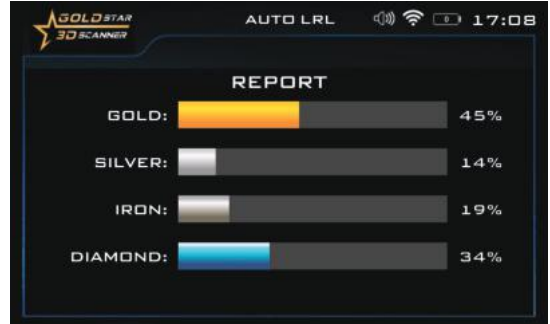

Control Long Range Locator System [CTRL LRL]

The control long range locator system is one of the new technologies and important features that have been integrated into the device, which enables the user to specify the exact value of the search frequency in MHz unit to search for a specific type of metal or target made of a specific mixture of metals, thus ensuring more accurate results when searching using this system, the user can set multiple values and options related to the search.



Select the system

To start using, select this system from the main menu and press the OK key. After selection, multiple screens will appear to set the settings for this system, namely:

Notice

Immediately after entering any search system from the main menu, A video will appear which notify the device's assembly steps. In case of any mistake in the assembly or installing a wrong part that does not fit the selected system, a warning video will appear on the device's screen regarding the exact error.



Soil Type

Using this option, the user can specify the type of soil in the area in which he wants to search.

The available soil types that have been added to this device are:

- Rock
- Neutral soil
- Mixed soil
- Metallic
- Clay
- Sandy
- Mineral
- Chalky

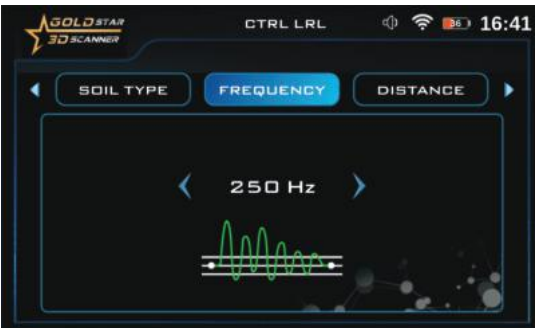

Notice

user can change value by 1000 steps by pressing up/down keys, and 250 steps by pressing left/right keys

Frequency

The user can manually adjust the search frequency value according to a specific target type using this option.

Frequency values range from 250Hz to 18000Hz Use the arrow keys to change the value and press OK

Note: The user can change the frequency value by 1000Hz by pressing the Up / Down arrow keys, or 250Hz arrow keys by pressing the Left / Right arrow keys.

Note: Every 1000Hz equals to 1kHz. For example, if user chooses 5000Hz it means 5kHz

Distance

The user can specify the distance to search within during the search process.

This means that the user can search within a radius of this distance, and this distance starts from 250 to 3000 meters

The distance value can be changed using the Left / Right arrow buttons and pressing OK

Note: The user can change the distance value by 250 for every press by pressing the Up / Down arrow keys, and by 50 meters by pressing the Left / Right arrow keys



Notice

user can change value by 250 steps by pressing up/down keys, and 50 steps by pressing left/right keys

Depth

It is the value of the maximum depth that the device can search.

The depth value can be set by choosing a value from a set of predefined values within the range from 0 to 50 meters.

Notice

User can change the depth value by 10 meters by pressing the Up / Down arrow keys, and by one meter by pressing the Left / Right arrow keys



Scan

After completing the previous settings, select the scanning tab using the arrow keys (Right and Left), then press the OK key above the "Start Scan" button.





How to Use

After the setup is completed, hold the device, as follows, and make sure that you are holding the device fixed to your body without moving, then stand in the search area and press the OK button on the keyboard to start the scanning process.

When you press the "OK" key on the keyboard in the previous window, the following screen will appear:

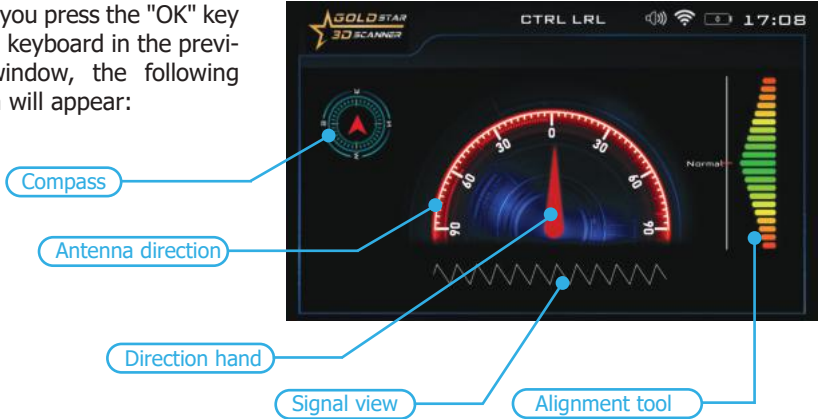

Compass: indicates the geographical direction of the device (north, south, east or west ...)

Antennas Indicator: It is a semi-circular indicator, the zero in the middle expresses the values of the angle of inclination of the antennas according to the direction to the right or left within a range from 0 to 90 degrees to the right and 90 degrees to the left.

Indicator Arrow: It is a red indicator that moves according to the angle of inclination of the antennas and indicates the specified value on the semi-circular indicator

Alignment tool: It is a color graded indicator from top to bottom and the zero point in the middle of it, expresses the angle of inclination of the device from the horizon and the correct values are shown in green

Notice

After assembling the device and before start to scan Make sure that the lock of antennas unit is open so that they are movable during use.

Antenna Holder Lock

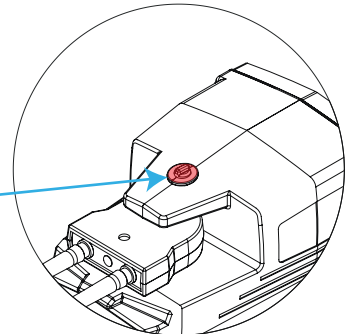

During the scanning process, the antennas will move left and right according to the target being detected.

The user should change his direction according to the direction of the antennas. Every movement will appear on the screen to make it easier for the user. The user must only follow the movement of the indicator arrow to get the correct direction, keeping in mind the device in a correct position with respect to the horizon.

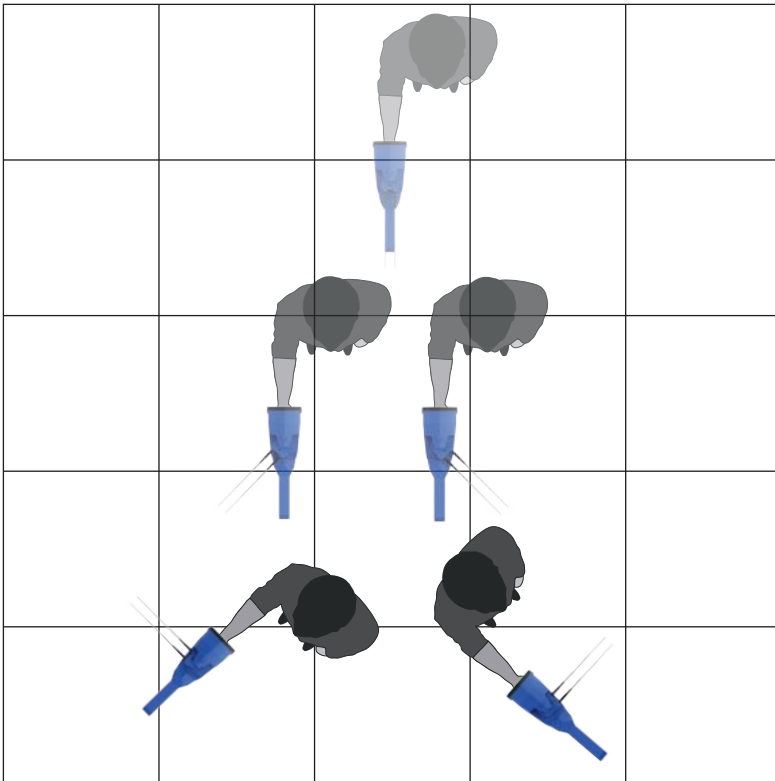

Manual Long Range Locator System [MANUAL LRL]

In the manual long range locator system, the search settings are adjusted manually by the user according to his preferences before the start of the search process, and many options can be customized.



Select the system

To start using, select this system from the main menu and press the OK key

After choosing, multiple screens will appear to set the settings for this system, which are:

Notice

Immediately after entering any search system from the main menu, A video will appear which notify the device's assembly steps. In case of any mistake in the assembly or installing a wrong part that does not fit the selected system, a warning video will appear on the device's screen regarding the exact error

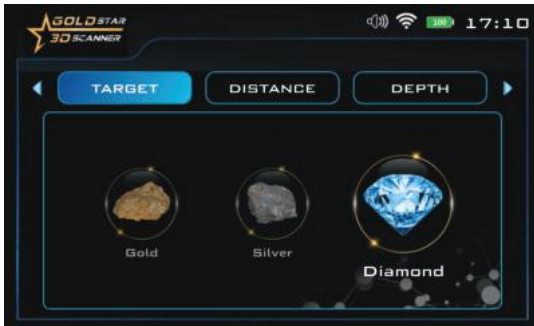

Target

It expresses the type of target to be searched for and can choose from predefined types. Below is the list of all device target types .

- Silver
- Platinum
- Iron
- Gold veins
- Gold treasure
- Gold ore
- Gemstone
- Diamond
- Copper
- Cavity
- Bronze

The target type is chosen by using the Left / Right arrow buttons and pressing OK



Distance

The user can specify the distance to search within during the search process.

This means that the user can search within a radius of this distance, and this distance starts from 250 to 3000 meters

The distance value can be changed using the Left / Right arrow buttons and pressing OK

Notice

The user can change the distance value by 250 meters by pressing the Up / Down arrow keys, and by 50 meters by pressing the Left / Right arrow keys

Depth

It is the value of the maximum depth that the device can search.

The depth value can be set by choosing a value from a set of predefined values within the range from 0 to 50 meters.

Notice

The user can change the depth value by 10 meters by pressing the Up / Down arrow keys, and by one meter by pressing the Left / Right arrow keys.



Scan

After completing the previous settings, select the scanning tab using the arrow keys (Right and Left), then click the "Start Scan" button, and then press the OK key.



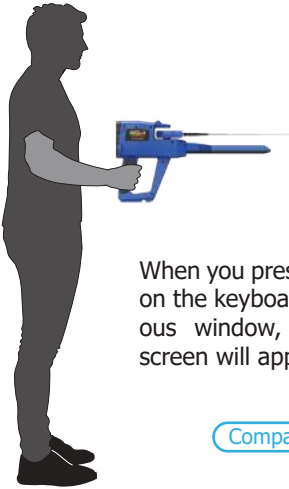

How to Use

After the setup is completed, hold the device, as follows, and make sure that you are holding the device fixed to your body without moving, then stand in the search area and press the OK button on the keyboard to start the scanning process.

When you press the "OK" key on the keyboard in the previous window, the following screen will appear:

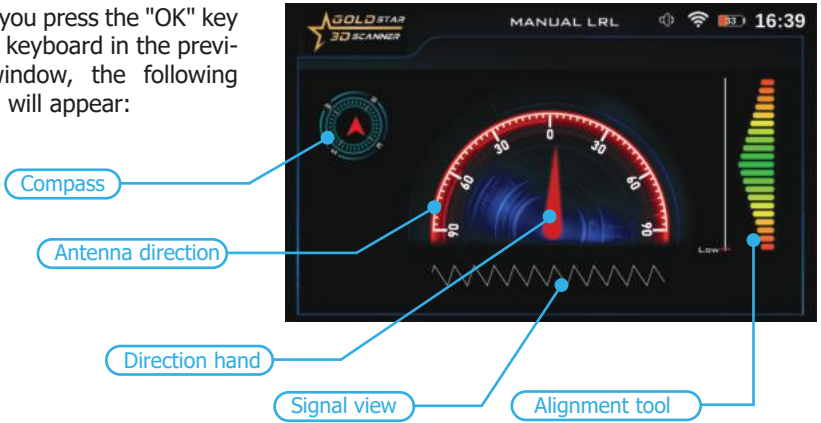

Compass: indicates the geographical direction of the device (north, south, east or west ...)

Antennas Indicator: It is a semi-circular indicator, the zero in the middle expresses the values of the angle of inclination of the antennas according to the direction to the right or left within a range from 0 to 90 degrees to the right and 90 degrees to the left.

Indicator Arrow: It is a red indicator that moves according to the angle of inclination of the antennas and indicates the specified value on the semi-circular indicator

Alignment tool: It is a color graded indicator from top to bottom and the zero point in the middle of it , expresses the angle of inclination of the device from the horizon and the correct values are shown in green

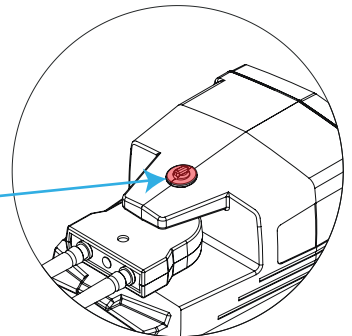

Antenna Holder Lock

Notice

After assembling the device and before start to scan Make sure that the lock of antennas unit is open so that they are movable during use.

During the scanning process, the antennas will move left and right according to the target being detected.

The user should change his direction according to the direction of the antennas. Every movement will appear on the screen to make it easier for the user. The user must only follow the movement of the indicator arrow to get the correct direction, keeping in mind the device in a correct position with respect to the horizon.

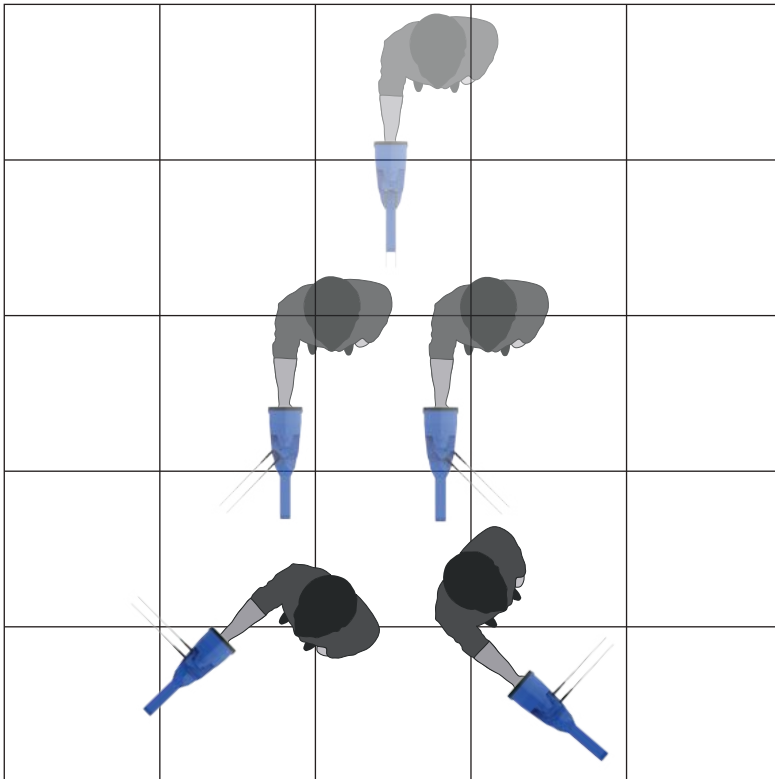

IONIC

The ionic search system has been developed according to a completely new technology, which is the first of its kind in metal detectors, and represents a major improvement over the traditional system that existed before.

Where the new technology allows more accurate detection of ion fields resulting from metal targets buried underground thanks to the Intelligent Multi Transceiver Unit (I.M.T.U) that ensures accurate reception and processing of signals, with the ability to control some of the signal settings on the screen to ensure accurate results.



Select the system

To start using, select the Ionic system from the main menu, then press the OK key

Notice

Immediately after entering any search system from the main menu, A video will appear which notify the device's assembly steps. In case of any mistake in the assembly or installing a wrong part that does not fit the selected system, a warning video will appear on the device's screen regarding the exact error

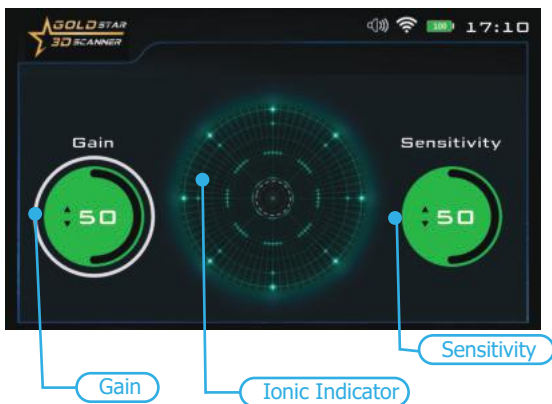

After the selection, a screen will appear, which includes the following elements:

Sensitivity

It is a signal sensitivity indicator presented in the form of a circular indicator whose value is in percentages.

During the search process, according to scanning the surrounding area in search for targets, the ionic system will make a special sound that represents the target's ability and is related to the value of the distance between the user and the target.

The user can change the sensitivity value at any time to be able to analyze the resulting sound, whose intensity changes according to the target distance.

Gain

It is a value that represents the signal strength and is represented in the form of a circular indicator whose value is also represented in percentages.

User can control signal strength using this option.

To set the device to detect large targets, decrease this value and increase this value for detection of small targets.

To select and change the two previous indicators, use the Left / Right arrow keys, then press OK. To change the value, use the Up / Down arrow keys and then OK.

Ionic Indicator:

It is an indicator in the form of two overlapping circles

How to Use

After the setup is complete, be sure to assemble the device exactly as shown in the assembly part of this manual.

Then hold the device like the image below.

During using this system, we press the start button to reset. Then we move the device slowly up and down with the same speed, while the device is slightly lowered towards the ground.

In the case of a close signal, it will appear on the ionic indicator in the screen, the indicator increases with the increase in the signal strength or as we approach the target, in conjunction with the issuance of a gradual acoustic alert, the increase in the signal strength the indicator appears in red if there are metals, and the indicator appears in blue if there are spaces.

To make sure the signal is correct, we do a reset by pressing the start button once, but in a different direction than the one from which the signal was picked up the first time, this step is repeated more than once, if the signal continues to appear, this means that the signal is completely correct.

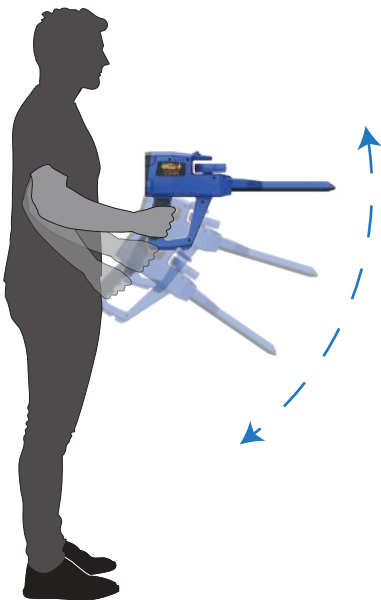

Warning

You should not reset the signal from the side, because we will lose the signal, and the device will deal with it as a normal level of the signal.

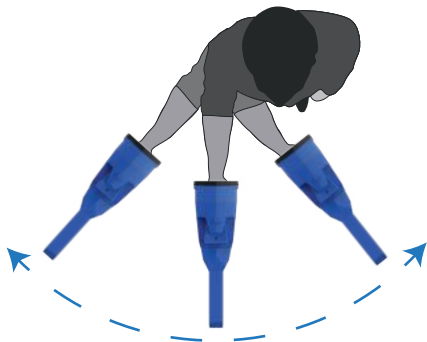

Notice

After assembling the device and before start to scan make sure that the antenna holder is locked to stop the holder rotation movement

Antenna Holder
Lock

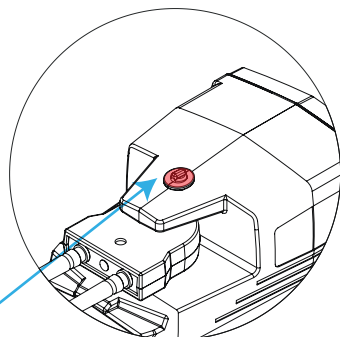

BIONIC

This search system is similar to the ionic search system in terms of working method and relying on the I.M.T.U unit to perform the scan.

The difference, however, is that here, ionic signals are captured from a specific metallic object. For example, from gold, then the search is directed towards capturing ionic signals similar to metal objects buried underground within the surrounding area.

That means, in the ionic search system, the search is random and free, but in the bionic system the search is directed according to a specific target type, that is, according to predefined signals.



Select the system

To start using, select the Ionic system from the main menu, then press the OK key

After the selection, a screen will appear, which includes the following elements:

Sensitivity

It is a signal sensitivity indicator presented in the form of a circular indicator whose value is in percentages.

During the search process, according to scanning the surrounding area in search for targets, the ionic system will make a special sound that represents the target's ability and is related to the value of the distance between the user and the target.

The user can change the sensitivity value at any time to be able to analyze the resulting sound, whose intensity changes according to the target distance.

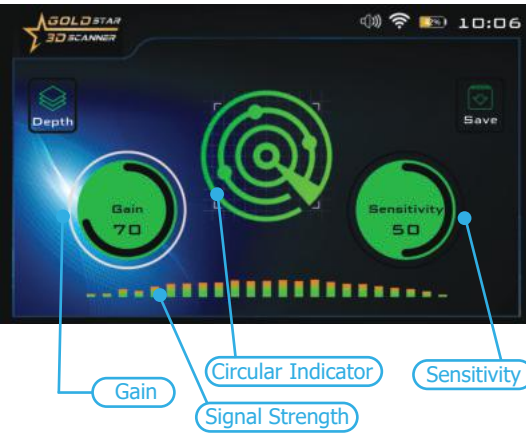

Gain

It is a value that represents the signal strength and is represented in the form of a circular indicator whose value is also represented in percentages.

User can control signal strength using this option. To set the device to detect large targets, decrease this value and increase this value for detection of small targets.

Circular Indicator:

It is an indicator in the form of four overlapping circles of different diameter, with four small circles on the outside of the second circle

Signal Strength Indicator:

It is a horizontal indicator made up of vertical rectangles whose heights and colors change according to the strength of the signal and the proximity of the targets

To select and change the two previous indicators, use the Left / Right arrow keys, then press OK. To change the value, use the Up / Down arrow keys and then OK.

How to Use

After the setup is complete, be sure to assemble the device correctly

Hold the device like the next figure

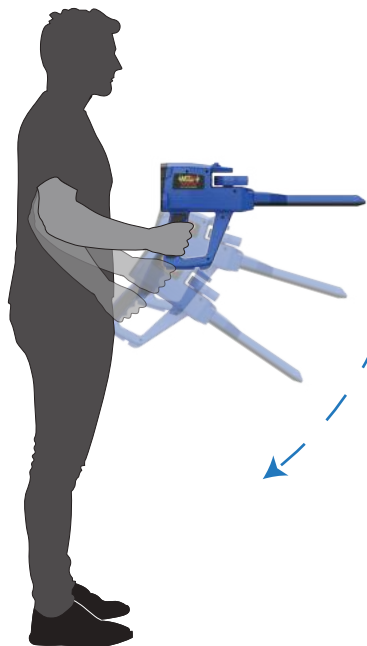

Point the IMTU head at the metal object of the model target type you want to find and then press the start button of the device, to set the target type.

By using this system, we move the unit of the ionic system in all directions slowly, in case there is a close signal, it will appear on the indicator.

The indicator in this system will appear stably in the event of a field similar to the field that was measured, in conjunction with a sound alert indicating the target.

In the event that the signal appears, it can be confirmed by returning to the first metal object and repeat the operation again.

Notice

There is no reset in this system, so in any point which we press the start button, will be the new field on which to match.

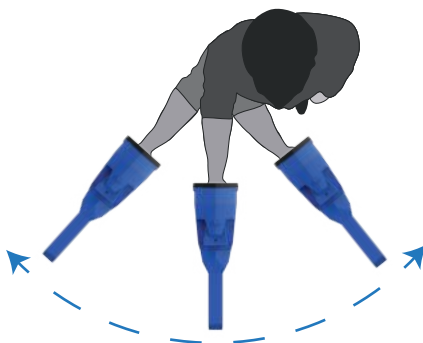

Notice

After assembling the device and before start to scan make sure that the antenna holder is locked to stop the holder rotation movement

Antenna Holder Lock

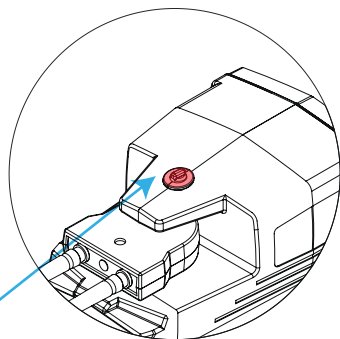

Live Stream System [LIVE STREAM]

A live stream is a system developed to detect various ferrous and non-ferrous metals in real time (real time), that is, in the form of a direct transmission with a direct visual representation of the signal according to a specific color that reflects the nature of the target, for example, precious metal, gold or tunnel.

The signal measurement process or the scanning process is done by the V.S.T (Vertical High Signal Transceiver) unit, which is a probe at the end of which there is a quadrilateral cone on both sides there are bars consisting of many light-emitting diodes or LEDs that change their colors according to target type that is, depending on the target that the V.S.T probe is passing over at this moment, for example, the LED lights will light up in blue when passing over a cavity or space such as a tunnel and light up red when passing over a precious metal such as copper or silver etc.

The signals captured by the V.S.T probe are represented on the screen of the device as a continuous color stream that changes colors according to the type of potential target. Similarly, the color will be red when capturing a precious metal signal, green for the ground, blue for the cavity ...

In conjunction with the color changing indicator, the device will make a sound tones according to the type of target whose signal was captured.

Also, the user can see a visual representation of the signals captured on any supported Android tablet via Multi Visual Analyzer that displays the signal plot in a graph and the color of the graph will change in a similar way depending on the nature of the signal, that is, the type of metal or target.

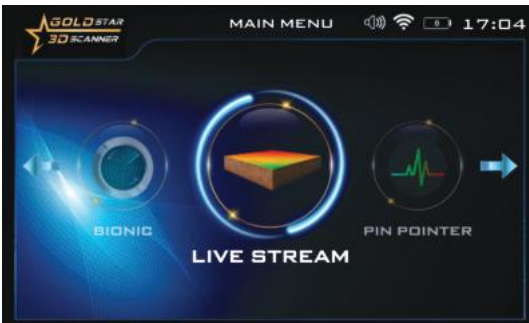

Select the system

To start using, select Live Stream system from the main menu and then press the OK key

Notice

Immediately after entering any search system from the main menu, A video will appear which notify the device's assembly steps. In case of any mistake in the assembly or installing a wrong part that does not fit the selected system, a warning video will appear on the device's screen regarding the exact error

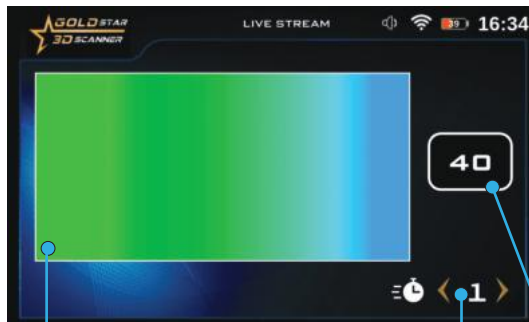

Notice

Use the Scanner Speed option to speed up / slow down the sensor scan speed. To use it after changing, press the start button of the device to set it

Scan Screen

Scan Speed

Scan value

How to Use

After the setup is complete, be sure to assemble the device exactly as shown in the assembly part of this manual. When setting up complete point the VST sensor vertically on the ground and start the scan process. Make sure that there are no metal objects in your shoes and keep the distance between the probe and the ground constant. also, during this procedure, the V.S.T Sensor should point vertically towards the ground, it should not rotate or pivot or even swing. during the operation you will see the color change in the device screen and according to the color change, the user can know whether there is a target underground or not.

On the right side of the screen, there is 3 boxes which are:

Value: It directly indicates the value of the signal captured by the search sensor. The colors of the indicator change according to the change of these values.





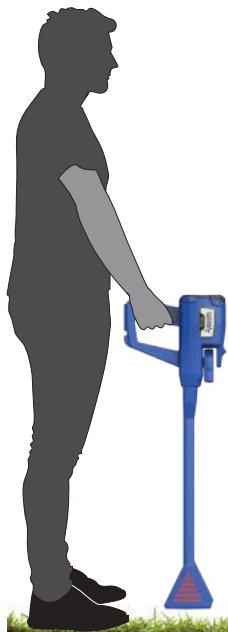

Speed: Use the scanner speed option to speed up / slow down the speed of the sensor scan, any change in the speed will ask the user to press the start button to apply the new changes.

Sensitivity: Use the sensitivity option to increase or decrease the sensitivity of the search sensor. Any change in the sensitivity will ask the user to press the start button to apply the new options.



During the Live Stream, the LED lights on the head of the V.S.T probe display the same color as the screen display, making it easier for the user to focus on the scan process instead of looking at the screen. The following is a description of the connotations of different colors:



		Green: normal natural ground
		Light Blue: a small cavity
		Blue: a larg voids like a tunnel
		Yellow: a small piece of metal object
		Red: gold or large pieces of metal target

Notice

In Live Stream system, the device was provided with a special technology, which is the possibility of full control of scan process through the Multi Visual Analyzer app. for more iformation folow Multi Visual Analyzer description on this user manual

PIN POINTER

This system is used to determine the presence of a metal target or cavity with the precise identification of the location in which the metal or buried cavity is located through a sound or graphic displayed on the screen or visual representation on the tablet.

The scanning process is conducted for potential targets via the V.S.T probe, but with the selection of the Pin Pointer System.

Select the system

To get started, select Pin Pointer System from the main menu and press OK

After the selection, a Pin Pointer system screen will appear, which includes the following elements:



Notice

Immediately after entering any search system from the main menu, A video will appear which notify the device's assembly steps. In case of any mistake in the assembly or installing a wrong part that does not fit the selected system, a warning video will appear on the device's screen regarding the exact error

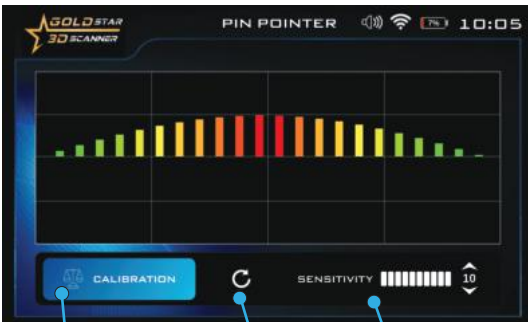

Calibration

Reset

Sensitivity

Sensitivity

During the search process and according to the target scan, the device will make a special sound tone with a graphical presentation on the screen that represents the presence of the target underground.

User can change the sensitivity value at any time to control the output sound and visualization on screen.

Calibration

User can use this option to calibrate the probe sensitivity at any time according to the type of ground and the condition of the area to be scanned.

Reset

Use this button to return the calibration to the default value.

How to Use

After the setup is complete, Point the head of the V.S.T probe vertically to the ground and begin to scan the ground.

Make sure that there are no metal objects in your shoes and keep the distance between the probe and the ground constant.

Also, during this procedure, the V.S.T probe should point vertically towards the ground, it should not rotate or pivot or even swing.

On the screen of the device, a bar graph is displayed that appears in green in the case of a natural ground, in the case of receiving metal signals, a graph which includes rectangles with different lengths will appear on top of horizontal center line

In the case of receiving underground cavities signals - such as a tunnel - they consist of rectangles facing downward of horizontal center line, of different lengths going to dark blue color.

On the screen of the device, some values that affect the scanning process can be controlled, such as sensitivity and calibration value.

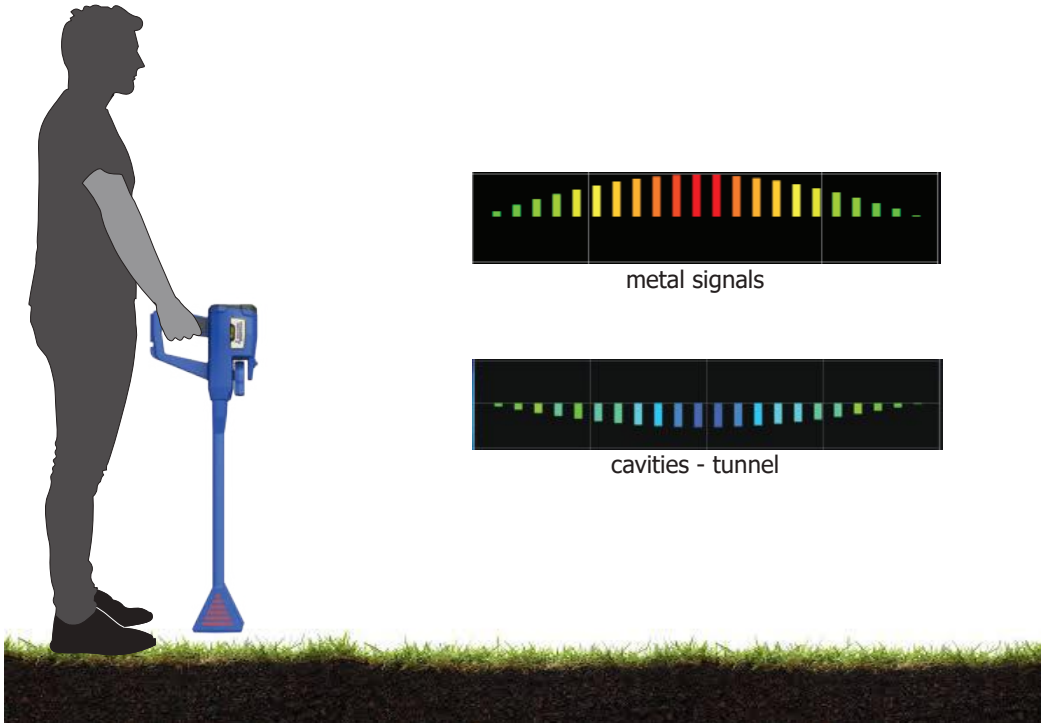

Multi Visual Analyzer

Introduction

One of the powerful options which is coming with new Mega Detection devices is the Android application. This application can show and analyze the scan result on the tablet or your mobile phone.

To start using Multi Visual Analyzer app you have to connect the tablet to the device.

Step 1: open settings on the tablet

Step 2: open connections Item

Step 3: open Wi-Fi from the list

Step 4: Select MEGA_GOLDSTAR_##### from the available networks

Step 5: Enter this password: **goldstar**

Step 6: open Multi Visual Analyzer app in tablet

note: if all 6 steps above done correctly you will hear a voice coming from the tablet saying: "CONNECTED SUCCESSFULLY"

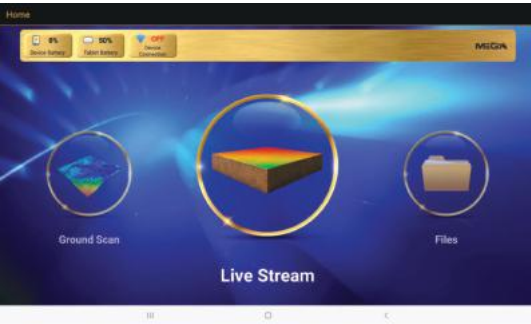
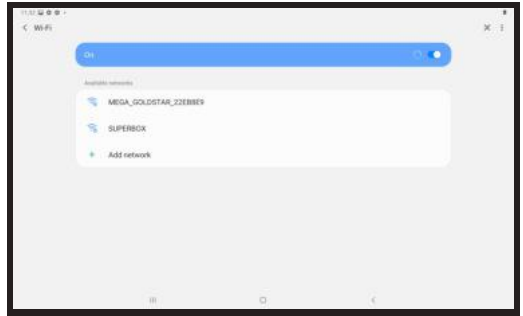

Multi visual analyzer application contains 4 options as below:

1. Ground scan
2. Scanned Files
3. Live Stream

Ground Scan

After selecting this item from the main menu the Mega Detection device screen will change like the picture below. Which is view the ground scan settings you are setting up in the application. And in the application screen you will see the below screen which includes six boxes to set before starting the scan job.

A.Width

It is the number of scan lines and can be set using the Up / Down arrows

B.Height

This number expresses the number of scanning steps or points for each line, and it can be changed by using the Up / Down arrows

C.Step Duration

When user is using automatic mode for scan mode, this option determines the time interval between two points

D.Start Point

This option determines that after each line complete user has to move to which side (ex. use left if you want to move to left side after each line complete)

**E.Scan Mode**

Here you can choose that you want to scan any point by pressing the Start button or you want the device to perform the scan automatically with the interval that is mentioned in part C.

F.Scan Pattern

This option includes two items (parallel & zigzag). User can choose which kind of pattern want to use during scan.

How to use

After complete settings press on Start Scan. Folow ground scan-how to use in this user manual for scan job

Notice

if the M.G.S.60 is not connected to the device you will se notification that you need to install is first.

If user choosed auto scan mode in settings,after each scan line will see the below alert.

To continue scan user has to move to next line and prees on Next Line button.

When user stop scan process an alert will appear which notify if you want to stop scan process.

By confirming this alert, scan view will ends and scanned file view will open (description for this view will come next)

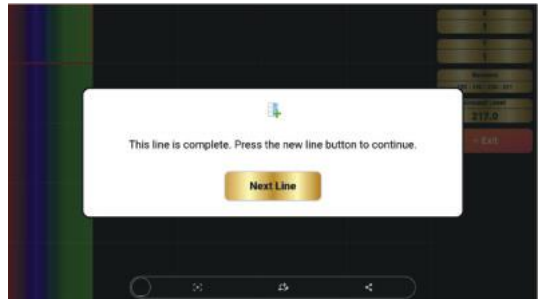

Files

After each ground scan job a file will create which includes all data about this job. This file is saved inside the device memory so when user open the scanned file within the android device the App will load this file(s) directly from the device. Using the android app for analysing this job is more powerfull and it gives the user to filter and measurement the result data easier. After selecting Files in main menu, a list of all saved scan files will appear. Touch on the file you need to analyze fo open it. As you see in the picture below.



Select any file you want to analyze from the files list , after opening any of the avaiable files , you can see the below screen which includes 8 options .

Wireframe

By pressing on this button, you can enable/-disable the wire frame mode for the 3D graph.

Data

Use this button to show / hide value data for each point on the 3D graph

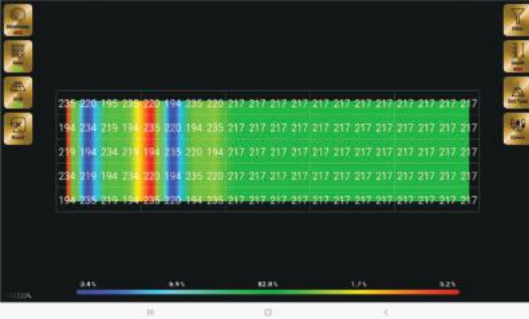

Grid

In case of user want to see each scanned point seperated, pressing on this button will draw a 2D graph which makes easy to seprate the scanned points.

Reset

Use this option to reset the 3D view

Filter

Use this optin to remove unneseccery colors(Green) from the 3D graph which it leavs the blue and the red colors.

Note: The color green represents ground without mineral or cavity value.

Depth

Use this optin to enable/disable depth value for each point on the 3D graph.

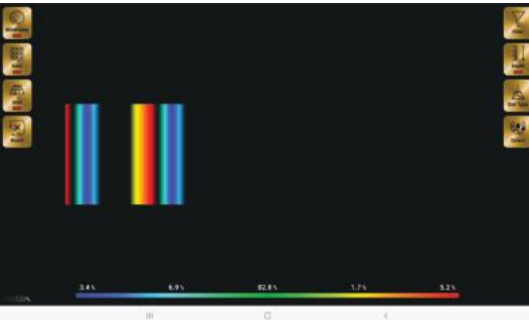

Dirt type (Soil Type)

To make the depth value exact , you need to choose the type of the land soil by using this option.

Colors

User can change the 3D graph colors using this option.

Start Scan

After Setting completes a screen with all selected options will appear on the device screen.

Notice

complete explanation about 3D ground scan comes in this user manual – Ground Scan section.

Live Stream

After selecting this item from the main menu the Mega Detection device screen will change like the picture below.

Notice

If the V.S.T probe is not connected to the device you will see notification that you need to install is first.

This screen includes three items.

1. Live Stream view: this view is showing the live stream result. Description about this view and colors in this box was coming in this user manual- Live Stream- How to Use.

2. Box for Live Value: in this box you can see the live signal captured by the V.S.T probe.

3. Calibration: use this button to calibrate the sensor sensitivity.

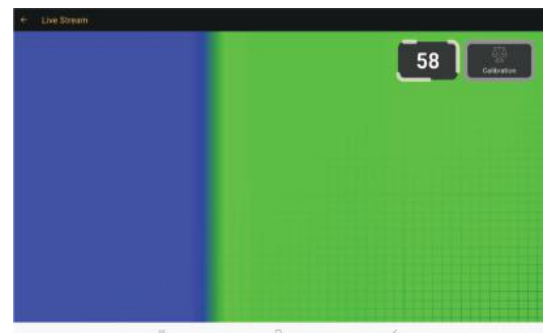

Settings

Click on Settings icon in the main menu to open settings screen, which includes the items below :



1. Language
2. Connection
3. Animated Background
4. About

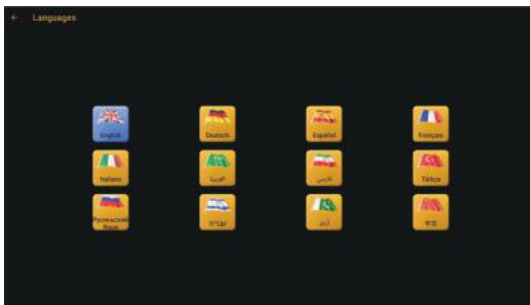

Language:

User can select favorite language using this option .You can see below the list of all available languages :

1. English
2. German
3. Spanish
4. French
5. Italian
6. Russian
7. Turkish
8. Chinese
9. Hebrew
10. Urdu
11. Arabic
12. Persian

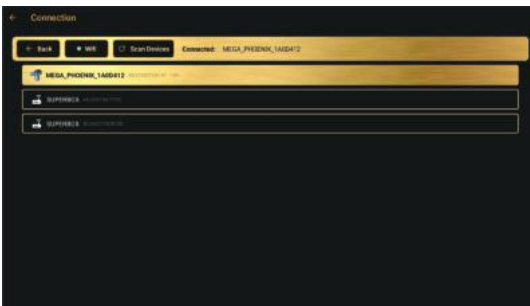

Connection:

Normally when the device is turned on, and user open the application on the Android device, a connection between both the device and the app will be established, but if not happened because of any reason, user can do it manually by using Connection item in the settings menu.

Animated Background

There is two different background types (Animation – Static) in the main menu that user can select it By enabling animated background using this option, you will see animated background in the main menu.



About:

This item includes short information about the Mega Detection company.

Customer Services

- All devices attached to the device are interchangeable by region and the customer center responsible for the service.
- You cannot apply the elements designed for this device with other devices.
- The user can obtain all auxiliary parts through GMI distributors after ensuring compatibility with the device. Sales and maintenance services are only available at GMI accredited centers. GMI is not responsible for the warranty or maintenance of any damage arising out of the use of accessories from other sources.
- You can get all information related to the use of the device and auxiliary parts by visiting the company's website.

The product or service guarantee will not be extended in the following cases:

1. If the product has been repaired, modified or changed, unless such repair, modification or change is authorized by MEGA DETECTION
2. If the product serial number is deformed or missing.

Specifications

Package	Package Dimensions	68 x 51 x 28 cm
	Package Weight	17 Kg
	Material	ABS Plastic
CPU	Processor Type	ARM 64 Bit
	Processor Frequency	1.4 Ghz
Memory	Storage Memory	32 GB
	Memory Type	SD Card
Screen	Screen Type	High Resolution TFT LCD
	Screen Size	5 Inch
	Screen Resolution	1024 x 860
	Colors	16 million
	Wi-Fi Connection	2.4 Ghz
Sound	Output	Speaker - Headset
	Jack Type	3.5 mm
	Headset	Wired Headphones
	Internal Speaker	Yes
Power	Battery Type	Lithium-Ion
	Battery Capacity	21000 mAh
	Fast Charging	No
	Removable Battery	Yes
	Languages	German – English – French – Spanish – Russian – Italian – Arabic – Hebrew – Persian – Turkish – Urdu - Chinese
Temperatures	Operation temperature	0°C – 40°C
	Storage temperature	-20°C – 60°C
	Humidity	5% – 75%

GOLDSTAR
3D SCANNER

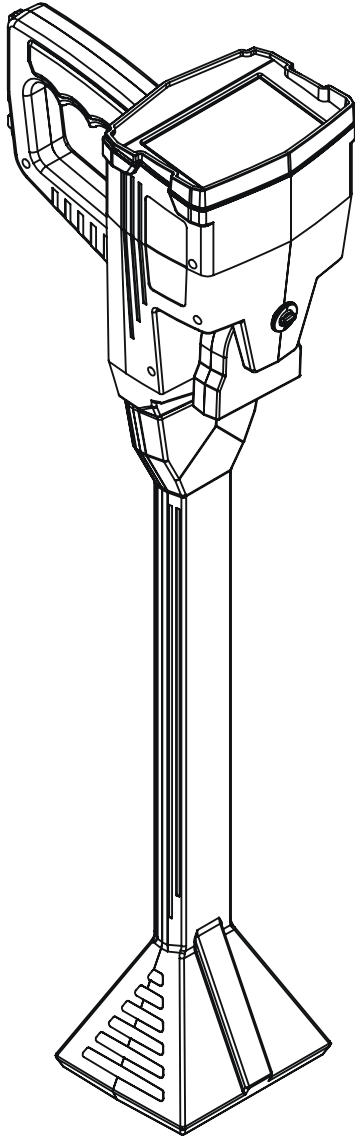

GOLDSTAR
3D SCANNER

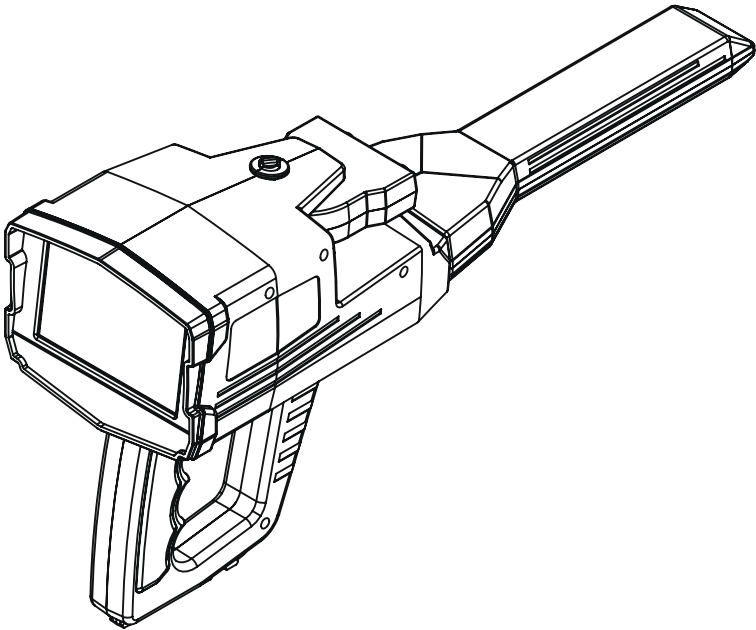



E-Mail : info@Megalocators.com
sales@Megalocators.com

Web : www.Megalocators.com

- You can buy this product from our distributors in all around the world
- You can visit our website to find the nearest distributor : www.Megalocators.com/where-to-buy
- For product validation you can check the product serial number by the link below : www.Megalocators.com/product-validation



Buy **GOLDSTAR 3D SCANNER**

The Warranty on the GOLDStar 3DScanner can be used to verify that your detector is genuine. Only GOLDStar 3DScanner detectors deliver the real results!

Verify your GOLDStar 3DScanner detector online at Megalocators.com

Product information correct at time of printing. Megadetection reserves the right to introduce changes at any time.

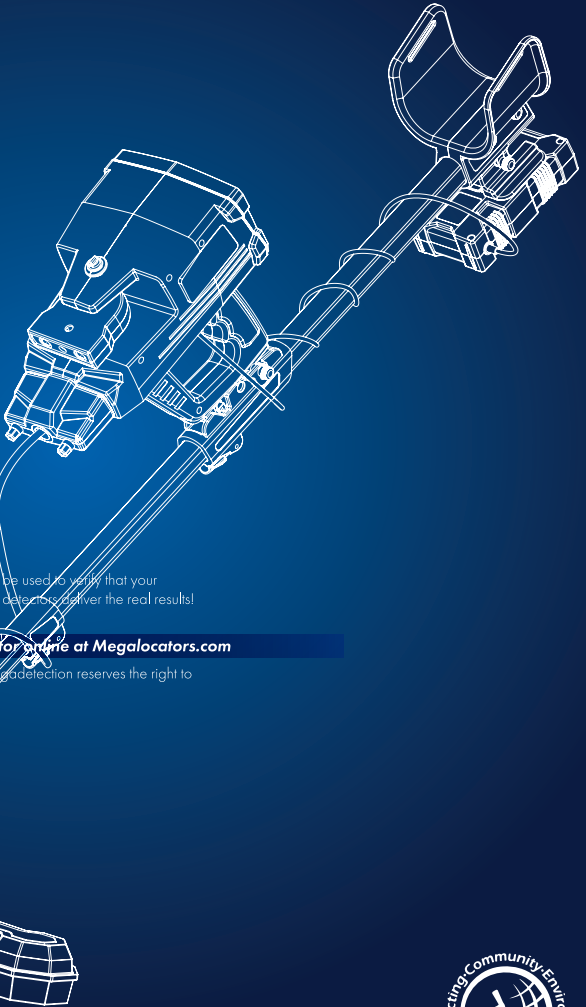

SEARCH SYSTEMS



GROUND SCAN



AUTO LRL



CTRL LRL



MANUAL LRL



IONIC



BUONIC



LIVE STREAM



PIN POINTER



The Most Powerful Gold And Treasures Technologies

